



Sesame Motor Corp., A leading brand in gear technology.

# MOTOR AND SPEED REDUCER



100%

Made in Taiwan

[www.sesamemotor.com](http://www.sesamemotor.com)



## Applications

### Applications of Planetary Gearhead

#### Machine Tools

Metal Cutting Machines, Machining Centers, CNC Drilling Machines, Lathes and Turning Machines, Milling and Boring Machines, Grinding Machines, Drilling Machines, Planning Machines, Metal Forming Machine Tools, Presses, Tube and Wire Processing Machines.

#### Industry Machinery

Packaging Machinery, Food and Beverage Processing Machinery, Bakery Equipment, Agricultural Machinery, Textile Machinery, Shoemaking Machinery, Wood Working Machinery, Printing Machinery, Plastic processing Machinery, Laser Cutting and Welding Machines.

#### Automation Equipment

Industrial Robots, Semiconductor Devices, Automatic Storage System, Surface Treatment Equipments.

#### Aerospace Industry

#### Medical and Rehabilitation Equipment

#### Electric Scooter

#### Green Energy-Related Industries

#### Testing Devices

#### Automation and Precise Positioning Equipment with Servo Motors

### Motor and Reducer

- Machine Tool Accessories • Cutting Equipment • Bar Feeder
- Gilding Machine • Conveyor Equipment • Food Machine
- Screen Printing • Agricultural Machinery • Medical Equipment

### Gear Motor and Reducer

- Machine Tool Accessories • Cutting Equipment • Bar Feeder
- Gilding Machine • Conveyor Equipment • Food Machine
- Screen Printing • Agricultural Machinery • Medical Equipment



# MOTOR TERM BRIEF INTRODUCTION

## Rating

Motor rating is the maximum allowance based on its temperature rising and loading. The Rating is including output, voltage, frequency, current, torque, speed and other related value. It can be classified continuously and short-time rating according to temperature limitation.

## Continuously & Short-time Rating

Time rating is defined via the motor works continuously with certain loading in ambient temperature 40°C and the motor temperature itself does not exceed the safe limit. Continuously rating means the motor can be operated continuously. Short-time rating means the motor can be operated within specified time interval only. Short-time rating motor with interval operation runs longer because of the thermal diffusion effects.

## Rated Output

Rated output means the motor works in a defined period of time with maximum loading and the motor temperature itself does not exceed the safe limit. For example, a 10HP continuous rating motor can be used as a 12HP or 13HP motor via the short-time rating usage. Thus it is marked rated output only. The RPM and torque under rated output formulation are justified as rated RPM and rated torque. The most suitable performance of motor is available only when the motor works in rated condition.

$$\text{Output} = 1.027 \cdot N \cdot T$$

$$1\text{HP} = 746 \text{ Watt}$$

1.027: Constant

N: Speed (RPM)

T: Torque (Kg · m)

## Starting Torque (see graph)

The torque produced by the motor when starting is called starting torque. The motor does not work if loading is larger than the starting torque.

## Maximum Torque (see graph)

The maximum torque is the most torque output of the motor under specified voltage and frequency. If the additional loading is larger than the maximum torque when the motor is running, the motor will stop immediately.

## Rated Torque (see graph)

The torque produced by the motor at rated output under specified voltage and frequency is rated torque. It is also the torque at rated speed.

## Rated Speed (see graph)

The measured speed of the motor at rated output.

## Motor Ingress Protection Rating

Model	Rating	Explanation
Wire Type	IP22	Prevent against object diameter > 12mm such as fingers Prevent against dripping water when tilted up to 15°
Terminal Box Type	IP54	Prevent against dust and it must not enter in sufficient quantity to interfere with the satisfactory operation of the equipment. Water splashing against the enclosure from any direction.

## Speed vs. Torque Graph

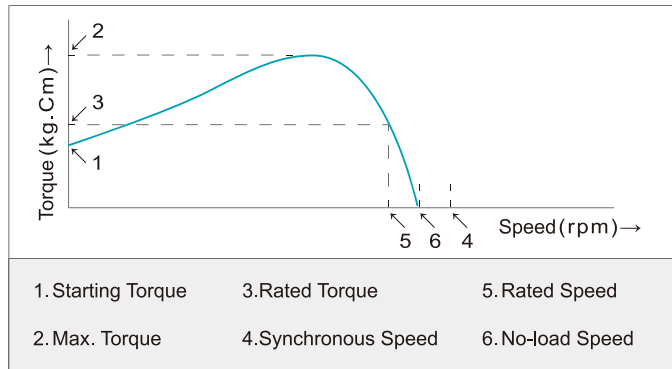

## Synchronous Speed (see graph)

Motor pole and power frequency will determine the speed. In general the unit is revolutions per minute (rpm). The calculation formula is:

$$N_s = \frac{120 \cdot f}{P}$$

$N_s$  : Synchronous Speed  
 120 : Constant  
 $f$  : Hertz (Hz)  
 $P$  : Motor Pole

Example: A 4-pole motor at 60 Hz, its synchronous speed is 1800 rpm.

## No-load Speed (see graph)

Motor speed under zero load is called no-load speed. Because of slip ratio, the speed of induction motor and reversible motor will be less than their synchronous speed (approx. 20 ~ 60 rpm less).

## Slip Ratio

An indication of motor speed.

$$S = \frac{N_s - N}{N_s}$$

$S$  : Slip Ratio  
 $N_s$  : Synchronous Speed (rpm)  
 $N$  : Designated Load Speed (rpm)

Example: If a 4-pole motor at 50 Hz pulling an object, its slip ratio is 0.1, then the motor speed is 1350 rpm.

$$N = \frac{120 \times 50}{4} (1 - 0.1) = 1500 \times 0.9 = 1350 \text{ rpm}$$

## Overrun

Overrun is the additional rotation after the power is turned off. It is indicated by turns or degree.

## Wiring Diagram

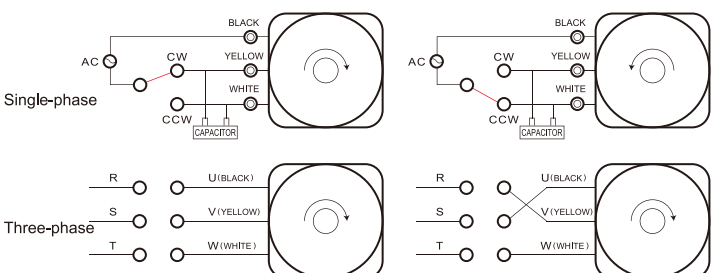

## POWER OUTPUT CALCULATION

### Belt Conveyor

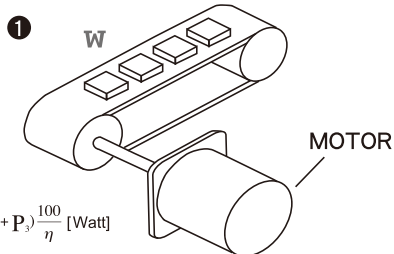

$$P_g = (P_1 + P_2 + P_3) \frac{100}{\eta} \text{ [Watt]}$$

No-load :

$$P_1 = 9.8\mu wvL \text{ [Watt]}$$

Horizontal :

$$P_2 = \frac{\mu QL}{367} \text{ [Watt]}$$

Vertical :

$$P_3 = \pm \frac{QH}{367} \text{ [Watt]}$$

- L : Length of conveyor(m)
- W : Weight of belt in unit length(kgf/m)
- $\mu$  : Friction coefficient
- V : Belt speed(m/sec)
- Q : Quantity(kgf/h)
- $\eta$  : Efficiency(%)
- H : Height difference between two ends of belt(m)

### Winding Up a Load

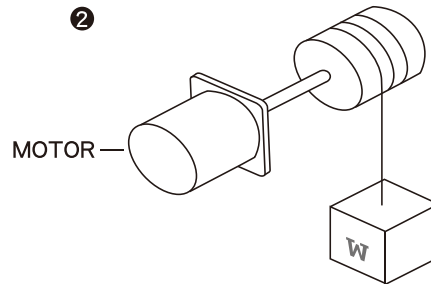

$$P_g = \frac{wv}{6.12} \cdot \frac{100}{\eta} \text{ [Watt]}$$

- W : Weight of belt in unit length(kgf/m)
- V : Belt speed(m/sec)
- $\eta$  : Efficiency(%)

### Horizontal Movement

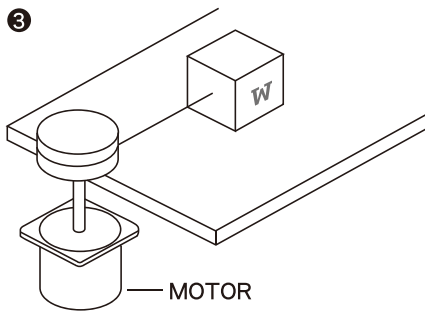

$$P_g = \frac{WV}{6.12} \text{ [Watt]}$$

- W : Weight of belt in unit length(kgf/m)
- $\mu$  : Friction coefficient
- V : Belt speed(m/sec)

### Driving of an Inertia Object

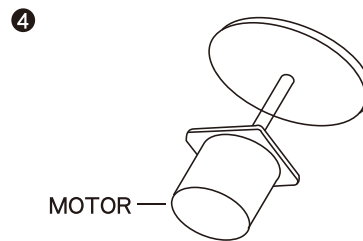

$$P_g = 1.027NT \text{ [Watt]}$$

$$T \approx \frac{GD^2}{375} \cdot \frac{N}{t} \text{ [kgf-m]}$$

- N : Revolutions per minute (rpm)
- T : Torque(kgf . m)
- GD<sup>2</sup> : Flywheel effect with rotor(kgf . m<sup>2</sup>)
- t : Starting time(sec)

### General Spec of Motor

Insulation Resistance	Test value above 100MΩ by DC500V hi-resistance meter at coil and housing after rated running at constant temperature and humidity.
Insulation Endurance	Hi-pot test by 60Hz 1.8KV for one minuate at coil and housing without damage after rated running at constant temperature and humidity.
Temperature Rise	Temperature rise below 75 °C after rated running.
Ambient Temperature Range	-10 °C ~ +50 °C (motor with capacitor -10 °C ~ +40 °C)
Insulation Class	E Class (120 °C)

# CHOOSING A SUITABLE MOTOR

## AC SMALL GEAR - SPEED REDUCED, VARIABLE SPEED, BRAKE MOTOR

AC MOTOR				
VARIABLE SPEED	<b>MODEL</b>	Variable Speed Brake Motor	Reversible Variable Speed Motor	Variable Speed Induction Motor
	<b>TURNING DIRECTION</b>	Forward or Reverse	Frequent Forward/ Reverse	Single Direction
	<b>BRAKE &amp; HOLDING FORCE</b>	Magnetic Brake & Holding Force	Minor Holding Force	No Holding Force
	<b>POWER SOURCE/ OUTPUT</b>	1 PHASE / 25W-90W <ul style="list-style-type: none"> <li>• A closed-circuit control system with motor and generator combined.</li> <li>• Wide range of speed.</li> <li>• Simple speed control, easy wiring.</li> <li>• Magnetic safety brake, great holding force.</li> </ul>	1 PHASE / 6W-60W <ul style="list-style-type: none"> <li>• A closed-circuit control system with motor and generator combined.</li> <li>• Wide range of speed.</li> <li>• Simple speed control, easy wiring.</li> <li>• Built-in easy brake function.</li> <li>• Frequent forward &amp; reverse.</li> </ul>	1 PHASE / 6W-90W <ul style="list-style-type: none"> <li>• A closed-circuit control system with motor and generator combined.</li> <li>• Wide range of speed.</li> <li>• Simple speed control, easy wiring.</li> </ul>
CONSTANT SPEED	<b>MODEL</b>	Brake Motor	Reversible Motor	Induction Motor
	<b>TURNING DIRECTION</b>	Forward or Reverse	Frequent Forward/ Reverse	Single Direction
	<b>BRAKE &amp; HOLDING FORCE</b>	Magnetic Brake & Holding Force	Minor Holding Force	No Holding Force
	<b>POWER SOURCE/ OUTPUT</b>	1 PHASE / 25W-90W <ul style="list-style-type: none"> <li>• Magnetic safety brake, great holding force.</li> <li>• Various models.</li> </ul> 3 PHASE / 25W-90W <ul style="list-style-type: none"> <li>• Magnetic safety brake, great holding force.</li> <li>• Various models.</li> </ul>	1 PHASE / 6W-60W <ul style="list-style-type: none"> <li>• Rated 30 mins.</li> <li>• <math>\frac{\text{Starting torque}}{\text{Rated torque}} = 0.8-1.0</math></li> <li>• Easy to switch directions.</li> <li>• Built-in easy brake system, minimized over run.</li> </ul>	1 PHASE / 6W-90W <ul style="list-style-type: none"> <li>• Continuous rating.</li> <li>• For general purposes</li> <li>• Multi-applications.</li> <li>• <math>\frac{\text{Starting torque}}{\text{Rated torque}} = 0.7-0.9</math></li> <li>• Various models.</li> </ul> 3 PHASE / 25W-90W <ul style="list-style-type: none"> <li>• High power, high efficiency.</li> <li>• Suitable for industrial machinery.</li> </ul>

★ Specifications subject to change without prior notice.      ★ Products with UL certification will be marked "UL" on the nameplates.

## PRODUCT NAME CODING SYSTEM

### ● INDUCTION MOTOR

4 I K 25 C GN - A M

#### ACCESSORIES

F: Fan M: Magnetic Brake  
 P: Thermo Switch  
 T: Terminal Box  
 Ts: Small Box(87L x 59W x 43Hmm)  
 TL: Large Box(132L x 55W x 50Hmm)  
 FF: Forced Fan

#### VOLT/ POLE

A: 1ø110V/4P B: 1ø110V/2P C: 1ø220V/4P  
 D: 1ø220V/2P CE: 230V~240V (50HZ)/ 4P  
 S: 3ø220V/4P T: 3ø220V/2P U: 3ø380V/4P V: 3ø380V/2P

#### SHAFT SHAPE

A: Round (Smooth) GN: Helical Gear  
 GX: Helical Gear  
 SW: Worm Gear  
 (For Clutch Brake Motor)  
 GK: Spur Gear Shaft GS: Spur Gear Shaft  
 (GS/GX for 60W/90W Only)

C: Torque Motor Assembled with Controller  
 R: Variable Speed

#### OUTPUT

6: 6W 15: 15W 25: 25W 40: 40W 60: 60W 90: 90W

#### MOTOR SERIES

K: K Series

#### TYPE

I: Induction R: Reversible  
 T: Torque (Controller is Separated from Torque Motor)

#### SIZE

2: 60mm 3: 70mm 4: 80mm 5: 90mm

# PRODUCT NAME CODING SYSTEM

## SPEED REDUCER



### ADD. SPECS

**H:** Heavy Duty **B:** Medium Loading  
**BH:** Heavy Duty Square Flange  
 BH \ H \ B are only available with 90mm frame size.

### BEARING TYPE

Precision Type:  
**KE:** Ball Bearing  
**BE:** Used For Both Self-Oiling Bearing and Ball Bearing  
 General Type:  
**K:** Ball Bearing  : Self-Oiling Bearing

### SPEED RATIO

**100:** 1/100 1/3 ~ 1/180 **10X:** Intermediate Speed Reducer

### GEAR TYPE

**GN:** Helical Gear **GX:** Helical Gear  
 GB series is suitable for BLDC motor.

### SIZE

**2:** 60mm **3:** 70mm **4:** 80mm **5:** 90mm



# INDUCTION MOTOR & SPEED REDUCER INSTALLATION MANUAL

## 1.Attention

### 1.1 Install preparation

- Please read this operation manual before using this motors. Any problems caused by inappropriate operation contrary with the manual, or damage caused by natural disasters, or restructure without our permission, Sesame will not take any responsibility nor will the motor / speed reducer be covered by warranty.
- Warranty is within one year after purchase. Within warranty period, if motor / speed reducer damage is not caused by operation error or by natural disaster, then please send back the product, we should replace the damaged spare part at free of charge.
- Before Installation, ensure correct voltage can be applied to motor.
- Do not bend the lead wires.
- Installation should be proceeded by trained technicians only.
- Please wire motor correctly according to the manual to prevent fire or electrical shock.
- Do not attempt to disassemble or modify the motor to prevent electrical shock or injury.

### 1.2 Installation Conditions

The conditions below must be fulfilled to avoid any motor damage, which is not covered under warranty.

- The motor was designed to be installed on the other facilities/applications.
- Do not expose the motor to flammable or corrosive gas.
- Indoor application only. Room temperature should be maintained between -10~50°C (-10~40°C for motor with capacitor)
- The air humidity should not exceed 85%.
- The altitude of where the motor was installed should not exceed 1000 meter above the sea level.
- Do not expose the motor to the sunshine directly. Dust and spray of oil/water is also forbidden.
- Avoid any continuous vibration or impact on the motor.
- Ensure the motor was installed in a well ventilated location.

### 1.3 Preparation of start up

- Please check the power supply before starting the motor.
- High temperature might cause the coil and bearing failed earlier.
- Do not connect the motor with inverter.
- Motor might be broken if wrong wiring or overloaded.

## 2.Installation

### 2.1 Round shaft model

- Mount the motor on the adapt plate by screws. Make sure the motor and the adapter were tightly mounted. (Note that screws for connecting motor and machine were not included)
- Please note that there should be no gap between motor and adapt plate.

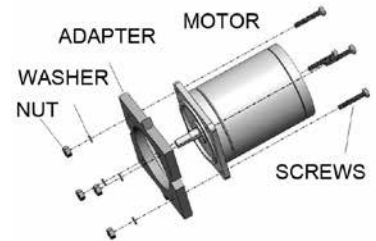

Flange dim $\square$ :	Screw	Tightening torque
60mm	M4	2.0 N · m
70mm	M5	2.5 N · m
80mm	M5	2.5 N · m
90mm	M6	3.0 N · m

### 2.2 Gear shaft model

Install motor and speed reducer by turning speed reducer left and right when gently inserting motor gear shaft into speed reducer until no gap between the mounting surfaces. Insert the screws and tighten them. No hammer or force is allowed.

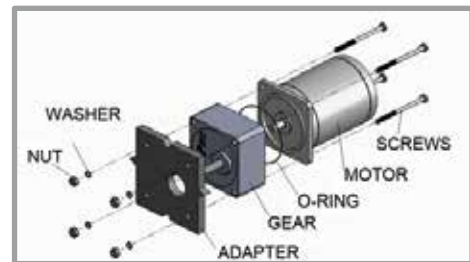

★O-rings are necessary for some specific models. Please install accordingly.

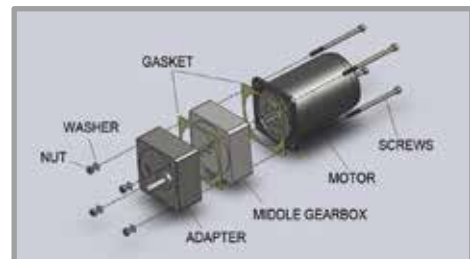

★Gaskets are required when installing intermediate speed reducer.

#### ⚠ Attention

- Metal chips/unconfirmed substance left inside speed reducer or incorrect installation will damage gears and results in abnormal noise, short lifespan or accident. Please be alert.
- Installation is available only when speed reducer and motor output shaft have the same gear type. Please confirm the specification of both products before installation.
- Specification compatibility check is required before applying both products to other machinery or equipment.
- Sesame Motor Corp. is not responsible for any cause there might occur if user's neglects of specification compatibility checking.



## 3. Wiring Diagrams

- The motor rotating direction was defined by looking toward the output shaft. In the forward direction for CW, reversed direction for CCW.
- 1 phase motor rotating direction change is available by switching wiring to CW. or CCW.
- 3 phases motor rotating direction change is available by switching any two wires of U, V, and W.

### 3.1 Induction / reversible motor

#### 3.1.1 3 phases

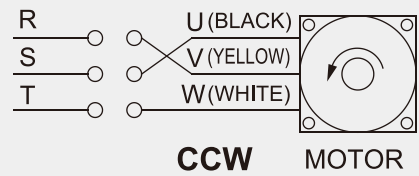
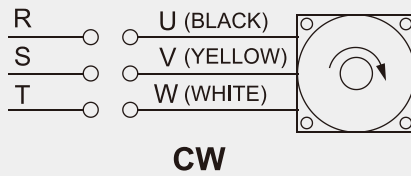

#### 3.1.2 1 phase

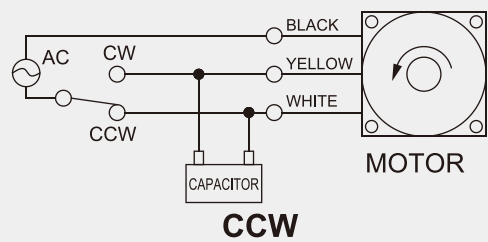
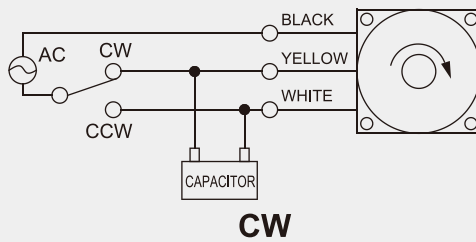

### 3.2 Brake motor



- ▶ The lining clearance will bigger than 0,3-0,35mm after a period of usage, please contact us to replace the lining.
- ▶ Isolating wiring is required when frequent braking condition.
- ▶ Brake frequency limit 10 times per minute.

#### 3.2.1 3 phases brake motor with terminal box. (220V / IP54)

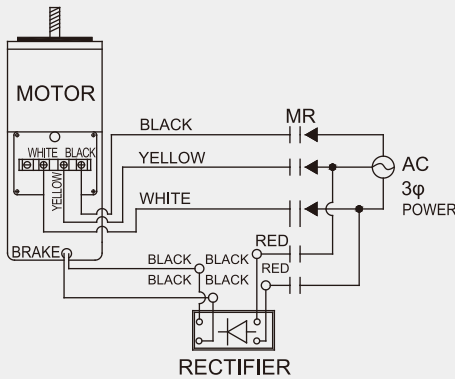

#### 3.2.2 3 phases brake motor with terminal box. (380V~460V / IP54)

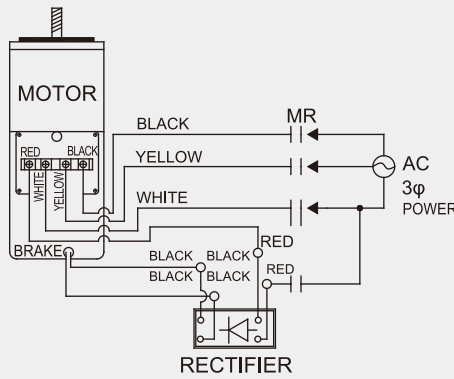

#### 3.2.3 3 phases brake motor with terminal box. (460V~600V / IP54)

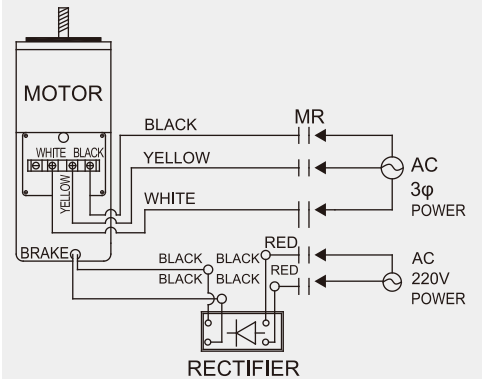

#### 3.2.4 3 phases brake motor (220V / IP22)

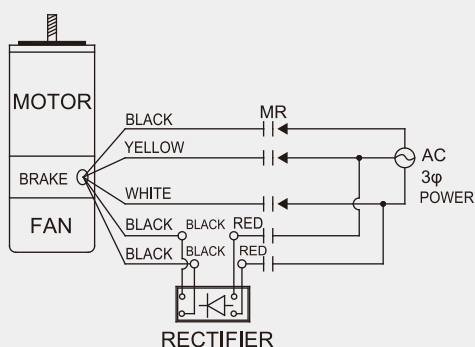

#### 3.2.5 3 phases brake motor (380V~460V / IP22)

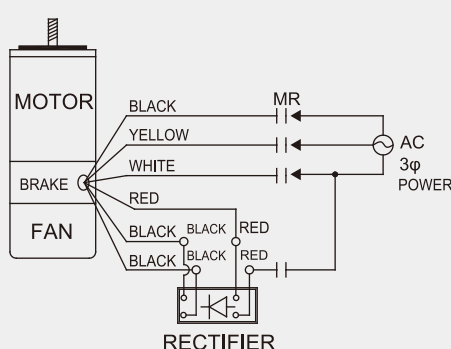

#### 3.2.6 3 phases brake motor (460V~600V / IP22)

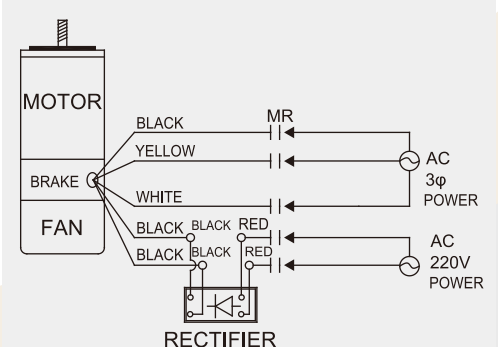

### 3. Wiring Diagrams

3.27  
3 phases brake motor (dual voltage)

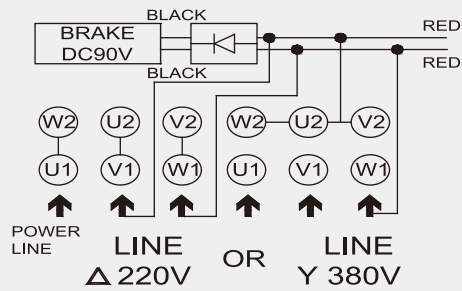

3.28  
1 phases brake motor with terminal box (IP54)

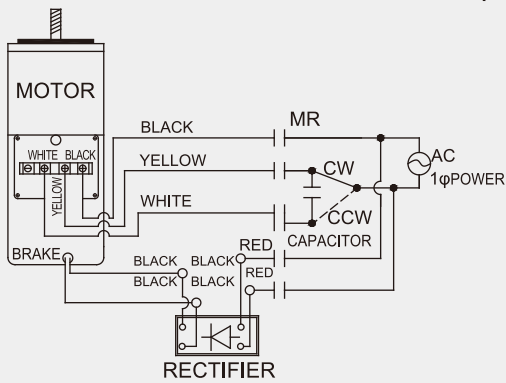

3.29  
1 phases brake motor (IP22)

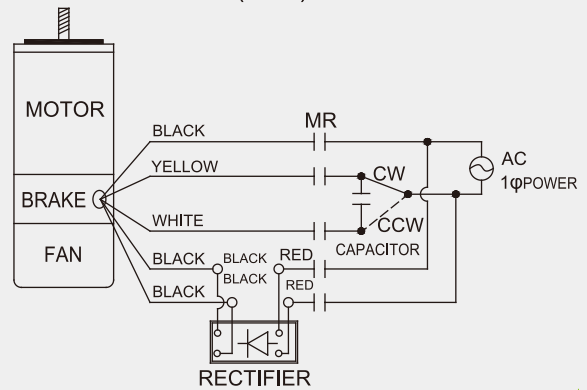

### 3.3 Torque motor

3.31 Standard type

- Motor rotating direction change is available by switching wiring to CW. or CCW.
- To adjust speed and torque, an external voltage regulator is needed.

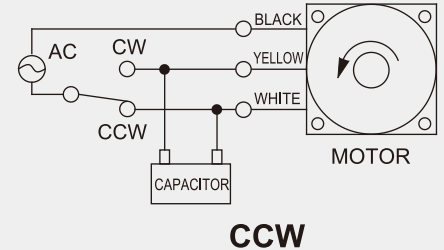
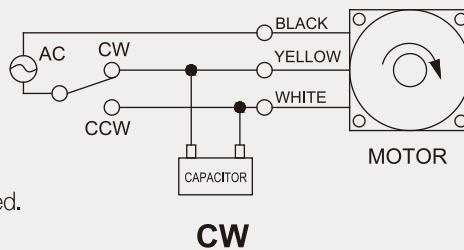

3.32 Terminal box type

- Voltage regulator is installed in terminal box. Motor speed adjust is available by attached speed controller.

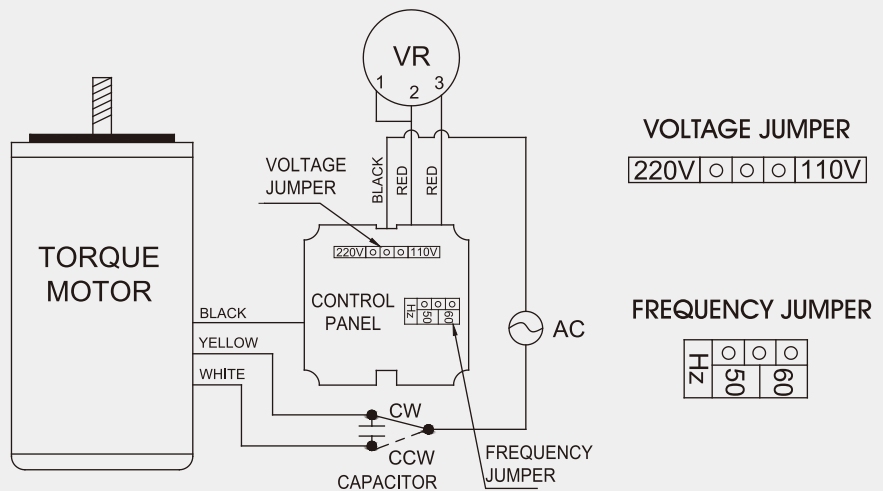

**Attention** Before operate terminal type torque motor, please make sure correct voltage and frequency jumper on the control panel to prevent motor burning down.

## 3.4 Clutch brake motor

- The power supply for motor (AC) and clutch brake (DC24V) must be separated.
- The output shaft keeps rotating when switch to clutch side after power supplied. As the switch is on the brake side, the brake will stop shaft rotation and keep great holding force.
- DC power off will release the brake and hence the output shaft rotates freely.

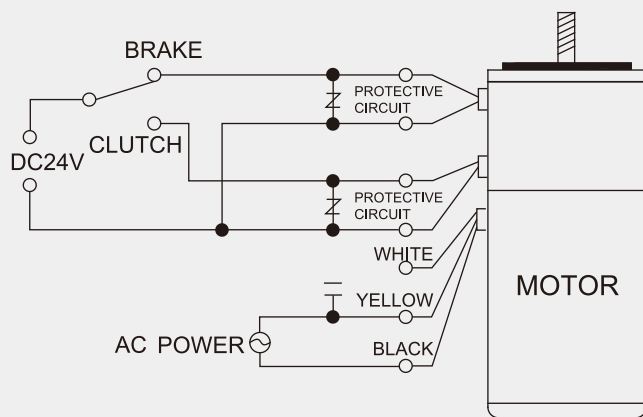

## 4. Installation of Capacitor (Single Phase Motor Only)

- Ensure the capacitor matches the specification of the motor before installation.
- Install the capacitor with M4 screws (not included).
- Capacitor should be installed inside the electrical box or IP54 rated box to avoid electric shock.



**Attention**

- ▶ To avoid damaging on the mounting foot, the screws tightening torque should not exceed 1 N.m.
- ▶ Install capacitor at least 10 cm away from motor to prevent heat damage to capacitor.
- ▶ Connect one wire in one terminal only.

## 5. Thermally Protected Motor Precaution

- Single phase thermally protected motor will restart automatically when motor temperature falls below a certain level. Always turn off the power before conducting checks or performing work on the motor.
- Thermal switch of three phases motor is installed with two red wires. Please connect two red wires to control system. Thermally protected motor will restart automatically when motor temperature falls below a certain level. Always turn off the power before conducting checks or performing work on the motor.

## 6. Trouble Shooting Guides

Please check the motor according to procedures below if abnormal situation.

- The motor does not work or the speed cannot be raised.
  - Check if the power supply fits the motor specification?
  - Confirm if the power supply is correctly connected?
  - Confirm if the motor is overloaded?
  - Confirm if the wires are poor connected when using crimping terminal or terminal block?
  - Confirm if the capacitor is well installed?
- The motor is over heated
  - Check if the power supply fits the motor specification?
  - Check if the room temperature is under the requirement ( $< 40^{\circ}\text{C}$ )?
  - Confirm if the capacitor specification is correct?
- Noise
  - Check if the motor was blocked?
  - Check if a phase failure occurs?
  - Check if brake well functioning?
  - Check if the fan loosens?
- If the problem could not be solved via the procedures above, please DO NOT take apart the products, contact Sesame for technical support.

## RK Series REVERSIBLE MOTOR

- Rated Time: 30 minutes
- Built-in Easy Brake System
- Frequent Forward/Reverse Usage
- Few Over Run, Minor Holding Force

### REVERSIBLE MOTOR, LEAD WIRE TYPE (6W-60W)

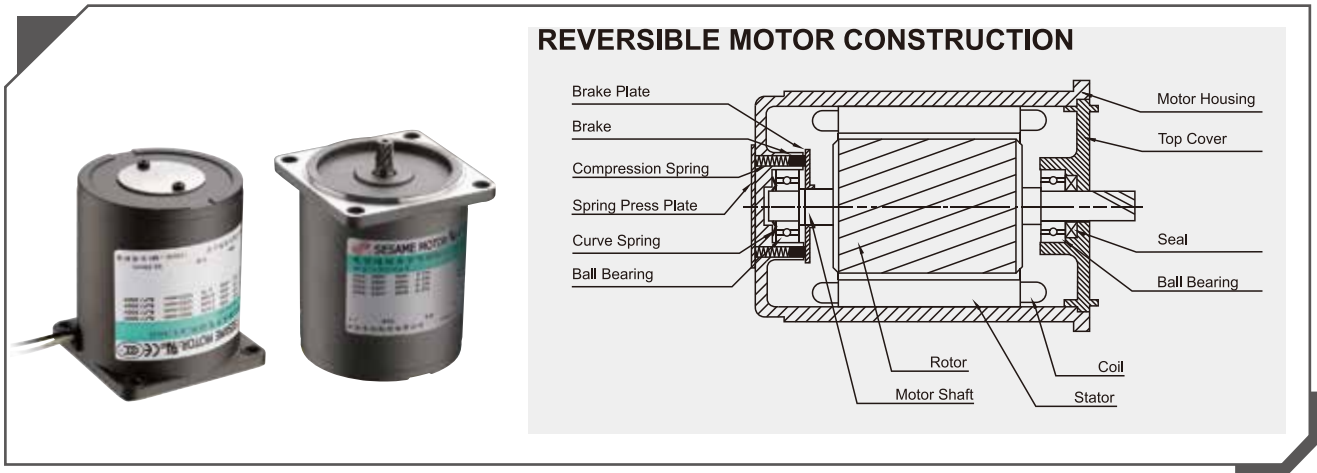

### REVERSIBLE MOTOR, TERMINAL BOX TYPE (6W-60W)

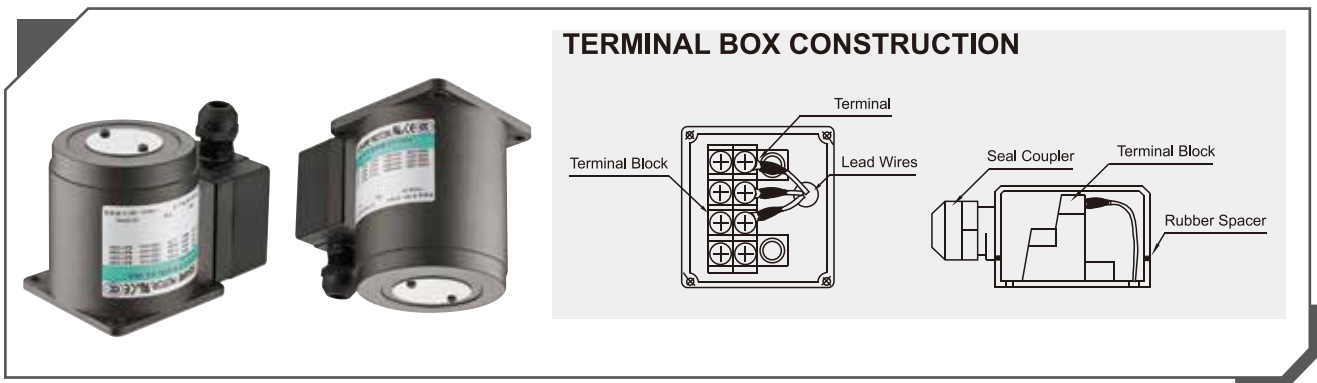

### REVERSIBLE MOTOR CURVE

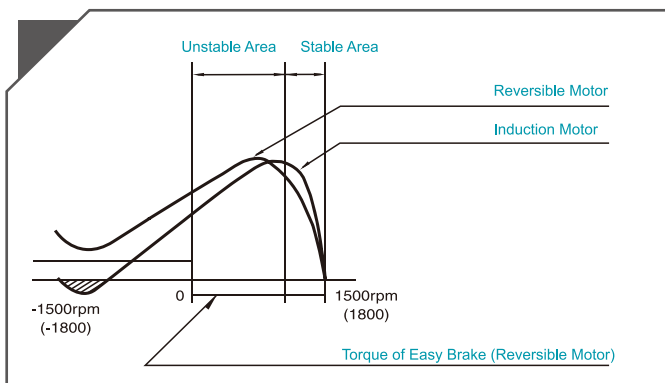

Notes : At 50Hz, a 4-Pole motor has synchronous turning speed of 1500rpm, 1800rpm at 60Hz.

### BRAKE TORQUE & OVERRUNS

OUTPUT (W)	BRAKE TORQUE (kg.cm)	OVERTURNS (TURNS)
6	0.59	4-6
15	1.27	4-6
25	1.47	4-6
40	3.92	4-6
60	3.92	4-6

※ FOR REFERENCE ONLY

## RK Series REVERSIBLE MOTOR, LEAD WIRE TYPE-IP22

■ OUTLINE & SPECIFICATION  
■ UNIT : mm

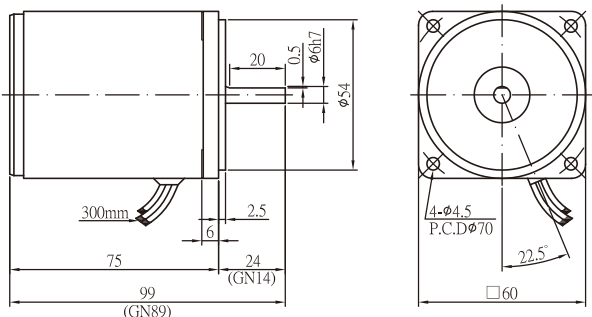

6W

6W MODEL	OUTPUT (W)	VOLTAGE (V)	FREQ. (HZ)	POLE (P)	RATED SPEED (rpm)	RATED TIME	STARTING TORQUE (Kg.cm)	RATED TORQUE (Kg.cm)	RATED CURRENT (A)	CAPACITY (μF)
2RK6A(GN)-A	6	1φ100/110	50/60	4	900/1150	30 /minutes	0.72/0.7	0.57/0.51	0.24/0.25	3.3/300V 3/300V
2RK6A(GN)-C	6	1φ200/220	50/60	4	1000/1300	30 /minutes	0.72/0.8	0.55/0.45	0.13/0.15	1/450V
2RK6A(GN)-CE	6	1φ230/240	50	4	1100/1050	30 /minutes	0.95/0.94	0.53/0.55	0.14/0.14	1/450V

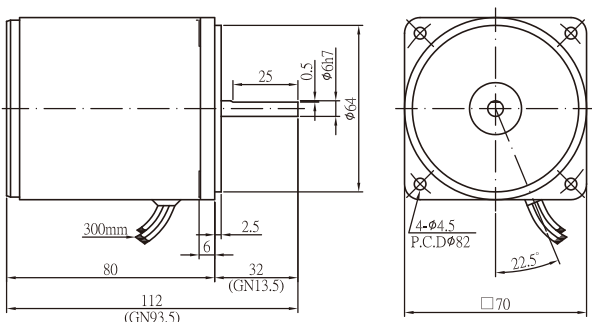

15W

15W MODEL	OUTPUT (W)	VOLTAGE (V)	FREQ. (HZ)	POLE (P)	RATED SPEED (rpm)	RATED TIME	STARTING TORQUE (Kg.cm)	RATED TORQUE (Kg.cm)	RATED CURRENT (A)	CAPACITY (μF)
3RK15A(GN)-A	15	1φ100/110	50/60	4	1200/1450	30 /minutes	1.17/1.24	1.16/0.95	0.37/0.44	6/300V
3RK15A(GN)-C	15	1φ200/220	50/60	4	1200/1450	30 /minutes	0.96/1.34	0.96/0.97	0.20/0.23	1.5/450V
3RK15A(GN)-CE	15	1φ230/240	50	4	1250	30 /minutes	1.36/1.31	1.14/1.19	0.19/0.21	1.5/450V

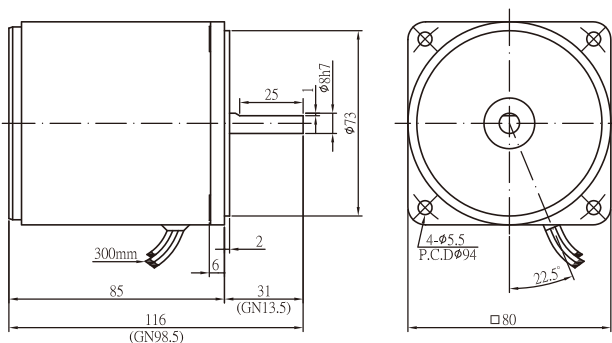

25W

25W MODEL	OUTPUT (W)	VOLTAGE (V)	FREQ. (HZ)	POLE (P)	RATED SPEED (rpm)	RATED TIME	STARTING TORQUE (Kg.cm)	RATED TORQUE (Kg.cm)	RATED CURRENT (A)	CAPACITY (μF)
4RK25A(GN)-A	25	1φ100/110	50/60	4	1250/1650	30 /minutes	1.65/1.92	1.95/1.48	0.56/0.51	8/300V
4RK25A(GN)-C	25	1φ200/220	50/60	4	1300/1600	30 /minutes	1.98/1.94	1.89/1.54	0.29/0.30	2.5/450V 2/450V
4RK25A(GN)-CE	25	1φ230/240	50	4	1350/1350	30 /minutes	2.22/2.19	1.8/1.82	0.25/0.25	2/450V

Products due to human error, natural disasters or other factors lead to poor or damaged, will not be covered under warranty.

# MOTOR AND SPEED REDUCER

GENERAL PURPOSE MOTOR

SPEED CONTROLLED MOTOR

CONTROLLER

BRAKE MOTOR

CLUTCH BRAKE MOTOR

TORQUE MOTOR

SPEED REDUCER

COMPONENTS

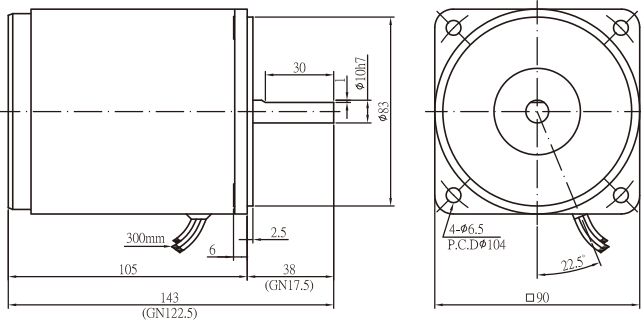

40W

40W MODEL	OUTPUT (W)	VOLTAGE (V)	FREQ. (HZ)	POLE (P)	RATED SPEED (rpm)	RATED TIME	STARTING TORQUE (Kg.cm)	RATED TORQUE (Kg.cm)	RATED CURRENT (A)	CAPACITY (μF)
5RK40A(GN)-A	40	1φ100/110	50/60	4	1050/1500	30 /minutes	2.43/3.1	2.83/2.64	0.99/1.01	12/300V
5RK40A(GN)-C	40	1φ200/220	50/60	4	1150/1500	30 /minutes	3.76/2.73	3.35/2.64	0.54/0.53	4/450V 3/350V
5RK40A(GN)-CE	40	1φ230/240	50	4	1150/1300	30 /minutes	2.41/3.17	3.36/3.04	0.49/0.44	3/450V

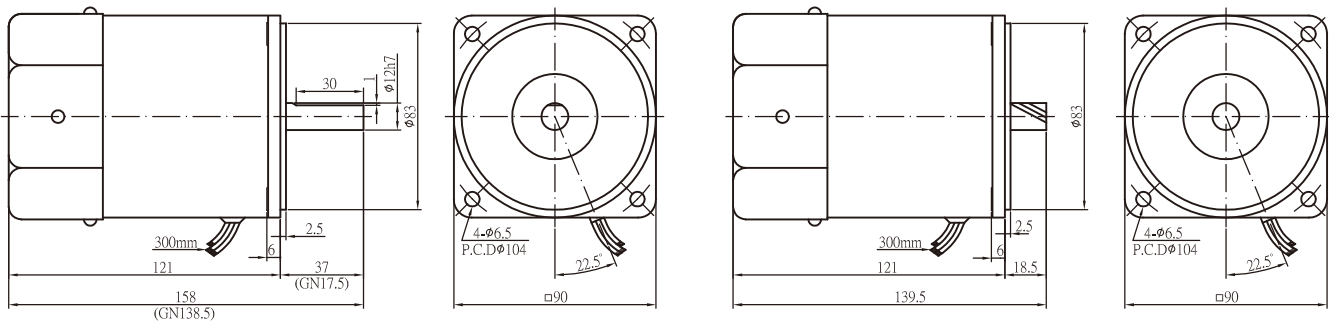

60W/60W-GX

60W/60W-GX MODEL	OUTPUT (W)	VOLTAGE (V)	FREQ. (HZ)	POLE (P)	RATED SPEED (rpm)	RATED TIME	STARTING TORQUE (Kg.cm)	RATED TORQUE (Kg.cm)	RATED CURRENT (A)	CAPACITY (μF)
5RK60A(GN, GX)-AF	60	1φ100/110	50/60	4	1300/1600	30 /minutes	3.08/4.03	4.82/3.78	1.34/1.25	16/300V
5RK60A(GN, GX)-CF	60	1φ200/220	50/60	4	1250/1600	30 /minutes	2.38/2.97	4.68/3.68	0.75/0.73	4/450V
5RK60A(GN, GX)-CEF	60	1φ230/240	50	4	1300	30 /minutes	4.33/4.72	4.59/4.6	0.57/0.63	4/450V

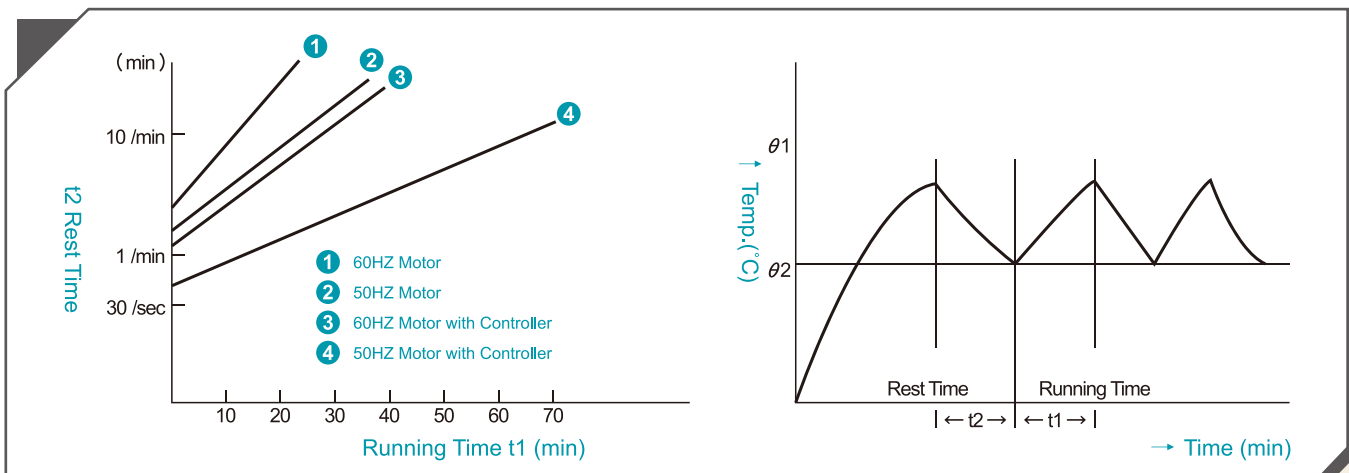

## REMARKS :

- "Rated Time" indicates the time limit to which the motor must stop running after its continuous operation, and resume to run only after cooling down. Otherwise, the motor may burn down due to overheating.
- Reversible motors can also be used according to the methods shown above.



## RK Series REVERSIBLE MOTOR, TERMINAL BOX TYPE-IP54

■ OUTLINE & SPECIFICATION  
■ UNIT : mm

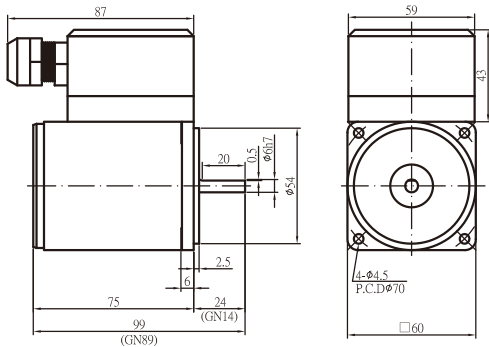

6W

6W MODEL	OUTPUT (W)	VOLTAGE (V)	FREQ. (HZ)	POLE (P)	RATED SPEED (rpm)	RATED TIME	STARTING TORQUE (Kg.cm)	RATED TORQUE (Kg.cm)	RATED CURRENT (A)	CAPACITY (µF)
2RK6A(GN)-AT	6	1ø100/110	50/60	4	900/1150	30 /minutes	0.72/0.7	0.57/0.51	0.24/0.25	3.3/300V 3/300V
2RK6A(GN)-CT	6	1ø200/220	50/60	4	1000/1300	30 /minutes	0.72/0.8	0.55/0.45	0.13/0.15	1/450V
2RK6A(GN)-CET	6	1ø230/240	50	4	1100/1050	30 /minutes	0.95/0.94	0.53/0.55	0.14/0.14	1/450V

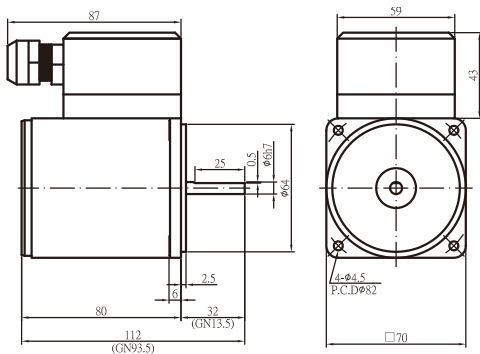

15W

15W MODEL	OUTPUT (W)	VOLTAGE (V)	FREQ. (HZ)	POLE (P)	RATED SPEED (rpm)	RATED TIME	STARTING TORQUE (Kg.cm)	RATED TORQUE (Kg.cm)	RATED CURRENT (A)	CAPACITY (µF)
3RK15A(GN)-AT	15	1ø100/110	50/60	4	1200/1450	30 /minutes	1.17/1.24	1.16/0.95	0.37/0.44	6/300V
3RK15A(GN)-CT	15	1ø200/220	50/60	4	1200/1450	30 /minutes	0.96/1.34	0.96/0.97	0.20/0.23	1.5/450V
3RK15A(GN)-CET	15	1ø230/240	50	4	1250	30 /minutes	1.36/1.31	1.14/1.19	0.19/0.21	1.5/450V

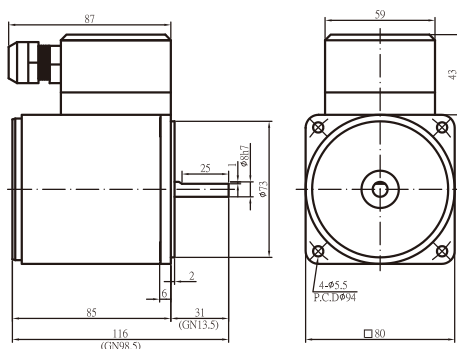

25W

25W MODEL	OUTPUT (W)	VOLTAGE (V)	FREQ. (HZ)	POLE (P)	RATED SPEED (rpm)	RATED TIME	STARTING TORQUE (Kg.cm)	RATED TORQUE (Kg.cm)	RATED CURRENT (A)	CAPACITY (µF)
4RK25A(GN)-AT	25	1ø100/110	50/60	4	1250/1650	30 /minutes	1.65/1.92	1.95/1.48	0.56/0.51	8/300V
4RK25A(GN)-CT	25	1ø200/220	50/60	4	1300/1600	30 /minutes	1.98/1.94	1.89/1.54	0.29/0.3	2.5/450V 2/450V
4RK25A(GN)-CET	25	1ø230/240	50	4	1350/1350	30 /minutes	2.22/2.19	1.8/1.82	0.25/0.25	2/450V

Products due to human error, natural disasters or other factors lead to poor or damaged, will not be covered under warranty.

# MOTOR AND SPEED REDUCER

GENERAL PURPOSE MOTOR

SPEED CONTROLLED MOTOR

CONTROLLER

BRAKE MOTOR

CLUTCH BRAKE MOTOR

TORQUE MOTOR

SPEED REDUCER

COMPONENTS

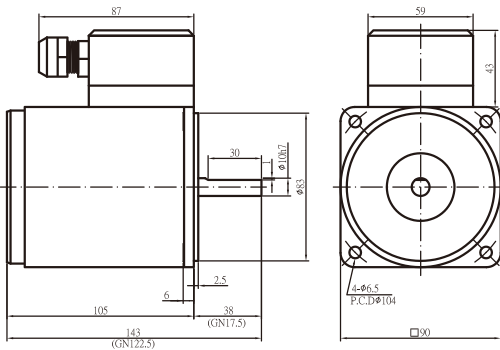

40W

40W MODEL	OUTPUT (W)	VOLTAGE (V)	FREQ. (HZ)	POLE (P)	RATED SPEED (rpm)	RATED TIME	STARTING TORQUE (Kg.cm)	RATED TORQUE (Kg.cm)	RATED CURRENT (A)	CAPACITY (μF)
5RK40A(GN)-AT	40	1φ100/110	50/60	4	1050/1500	30 /minutes	2.43/3.1	2.83/2.64	0.99/1.01	12/300V
5RK40A(GN)-CT	40	1φ200/220	50/60	4	1150/1500	30 /minutes	3.76/2.73	3.35/2.64	0.54/0.53	4/450V 3/450V
5RK40A(GN)-CET	40	1φ230/240	50	4	1150/1300	30 /minutes	2.41/3.17	3.36/3.04	0.49/0.44	3/450V

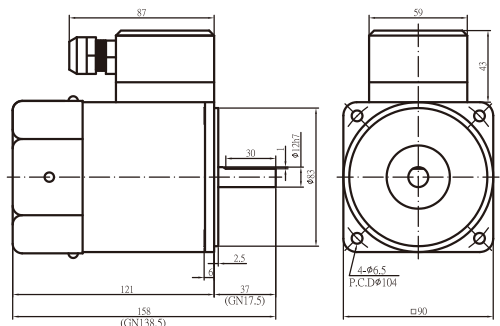

60W

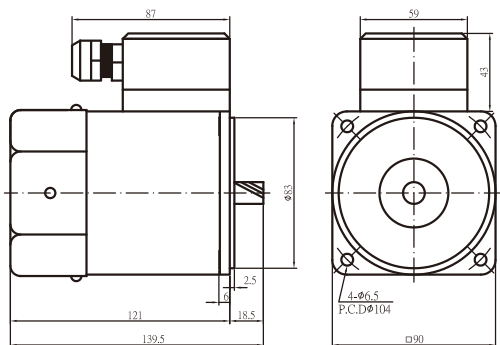

60W-GX

60W/60W-GX MODEL	OUTPUT (W)	VOLTAGE (V)	FREQ. (HZ)	POLE (P)	RATED SPEED (rpm)	RATED TIME	STARTING TORQUE (Kg.cm)	RATED TORQUE (Kg.cm)	RATED CURRENT (A)	CAPACITY (μF)
5RK60A(GN, GX)-AFT	60	1φ100/110	50/60	4	1300/1600	30 /minutes	3.08/4.03	4.82/3.78	1.34/1.25	16/300V
5RK60A(GN, GX)-CFT	60	1φ200/220	50/60	4	1250/1600	30 /minutes	2.38/2.97	4.68/3.68	0.75/0.73	4/450V
5RK60A(GN, GX)-CEFT	60	1φ230/240	50	4	1300	30 /minutes	4.33/4.72	4.59/4.6	0.57/0.63	4/450V

## REMARKS :

- "Rated Time" indicates the time limit to which the motor must stop running after its continuous operation, and resume to run only after cooling down. Otherwise, the motor may be burn down to overheating.
- The usage of the reversible motor (terminal box type) is the same as the reversible motor (lead-wire type).

# SPEED REDUCER ■ OUTLINE & SPECIFICATION

■ UNIT : mm

## HOW TO SELECT A SPEED REDUCER

### ■ ROTATION AND TORQUE GIVEN FROM CONJUNCTION WITH SPEED REDUCER

Following is the calculation formula:

$$\text{Rotations : } N_G = \frac{N_M}{i}$$

$$\text{Torque : } T_G = T_M \cdot i \cdot \eta$$

$N_G$  : Rotations after conjunction with speed reducer (rpm)

$N_M$  : Rotations of motor (rpm)

$i$  : Ratio

$T_G$  : Torque after conjunction with speed reducer (kg·cm)

$T_M$  : Torque of motor (kg·cm)

$\eta$  : The transmission efficiency of speed reducer

### ■ MAXIMUM TORQUE ALLOWED

The maximum torque a speed reducer can tolerate is limited due to materials or other specs. Please see the specification of speed reducer for maximum torque allowed at different ratio.

### ■ ALLOWABLE RADIAL LOAD AND AXIAL LOAD

Radial load refers to the bending load of output shaft at the 1/2 point, commonly used in units linked by chains. Radial load can be disregarded if a coupling is used. Do not over-load since radial load and axial load may affect service life and strength.

### ■ ADJUSTED THE SPEED REDUCER RATIO VIA ENVIRONMENT TEMPERATURE

Transmission efficiency of a speed reducer apparently does affected by the environment temperature. The graphic display the torque loss percentage at different ambient temperature (for reference only).

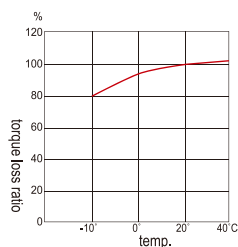

### ■ MOTOR EQUIP WITH ROUND SHAFT AND GEAR SHAFT, ONLY GEAR SHAFT CAN CONJUNCT WITH SPEED REDUCER.



### ■ LOAD PATTERNS VS. LIFESPAN OF SPEED REDUCER

Speed Reducer lifespan will vary by ways of loading including but not limit to operation time frame, different type of bearing. The following table assumes that the load gear is under the maximum permissible torque. (Reference for engineers)

Unit : hrs

LOAD PATTERN	BEARING			BALL BEARING			Application instructions
	5 hrs/day	8 hrs/day	24 hrs/day	5 hrs/day	8 hrs/day	24 hrs/day	
FIXED LOAD	2000	1500	1000	6250	5000	3400	Operated in one direction, such as conveyors.
SLIGHT IMPACT	1500	1250	800	4200	3400	2500	Frequent start/stop, ex. cam operator.
STRONG IMPACT	800 ~1000	700 ~1000	600 ~700	2000 ~2500	1700 ~2500	1400 ~1700	Reversible motors, instant moment reversed, with brake system in an instant brake.

Products due to human error, natural disasters or other factors lead to poor or damaged, will not be covered under warranty.



# SPEED REDUCER

■ OUTLINE & SPECIFICATION  
 ■ UNIT : mm



## ■ 5 GX□KB / SPEED REDUCER

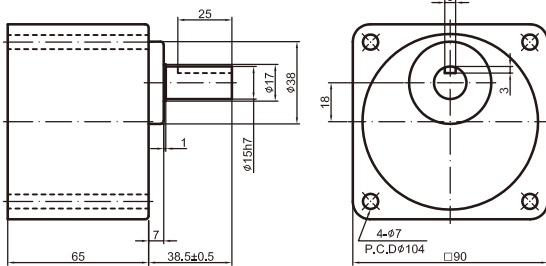

## ■ 5GX10XK / INTERMEDIATE SPEED REDUCER

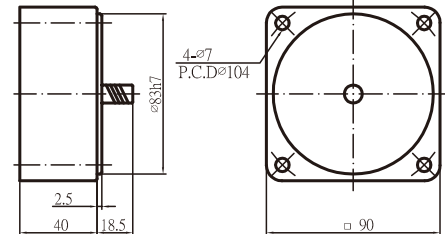

## ■ 5 GX□K / SPEED REDUCER

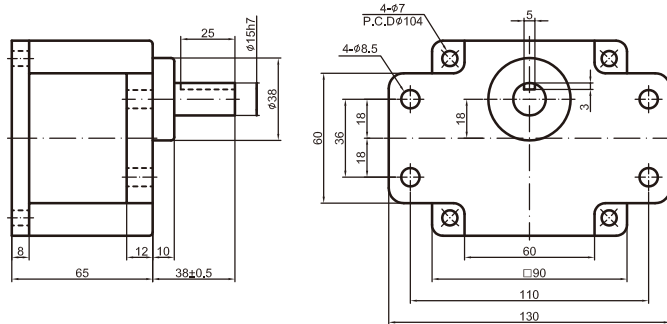

SPEED(rpm)	500	300	200	120	100	90	75	60	50	30	20	15	10	9	7.5
SPEED REDUCTION RATIO 50HZ	3	5	7.5	12.5	15	-	20	25	30	50	75	100	150	-	200
SPEED REDUCTION RATIO 60HZ	3.6	6	9	15	18	20	-	30	36	60	90	120	180	200	-
MAX. TORQUE(kgf.cm)	15	26	38	57	69	69	86	103	124	200	200	200	200	200	200

## ■ 5 GX□KBH / GRAVITY FORCE TYPE REDUCER

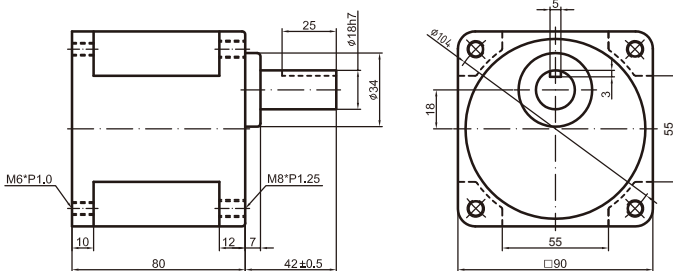

SPEED(rpm)	30	20	15	10	9	7.5
SPEED REDUCTION RATIO 50HZ	50	75	150	150	-	200
SPEED REDUCTION RATIO 60HZ	60	90	180	120	200	-
MAX. TORQUE(kgf.cm)	350	350	350	350	350	350

### NOTES :

1. Please fill in the required speed reduction ratio in the □ (square) after the speed reducer model no.
2. Rotational speed is calculated by dividing the synchronous speed of the motor (50Hz: 1500rpm; 60Hz: 1800rpm) with the reduction ratio. Depending on total load, actual rotational speed is 2%~20% less.
3. Speed reducers marked in the highlighted areas have opposite rotational direction to the motor. Others unmarked have the same rotational direction as the motor.
4. Attention: metal chips or objects in speed reducer will result in gear damage, noise and shorten service-life when assembling with motor.
5. Please make sure that the shaft size of the motor matches to that of the accompanying reducer model before assembly, otherwise inconformity will occur.

## COMPONENTS

### L TYPE BASE BRACKET FOR MOTOR INSTALLATION



PAL-3N (□70mm)

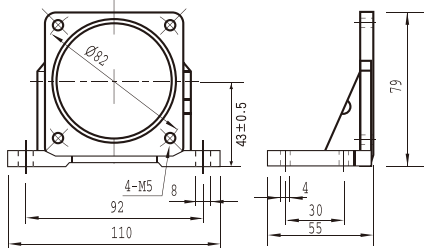

PAL-4N (□80mm)

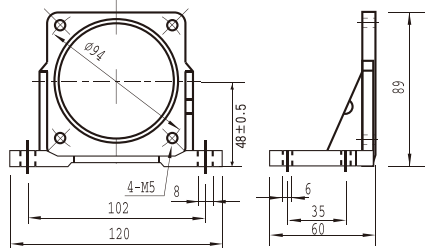

PAL-5N (□90mm)

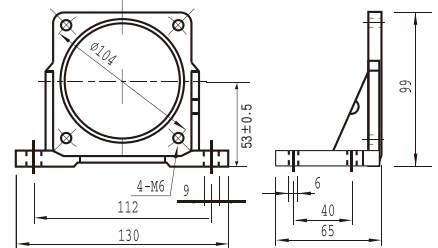

### EXTERNAL RESISTOR FOR ELECTRONIC BRAKE CIRCUITS

DDR10W10Ω J (10/10)

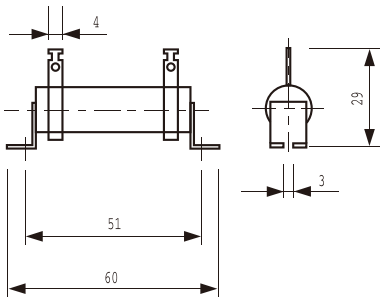

DDR20W20Ω J (20/20)

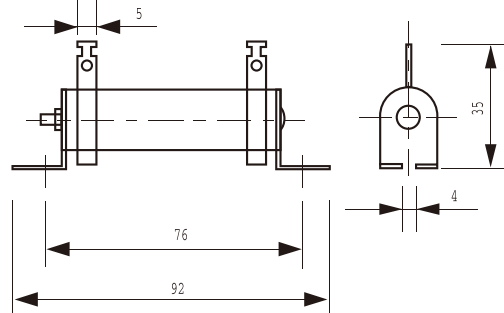

DDR30W20Ω J (30/20)

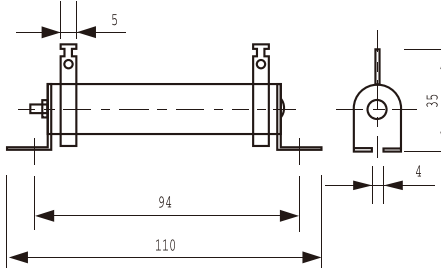

DDR50W50Ω J (50/50)

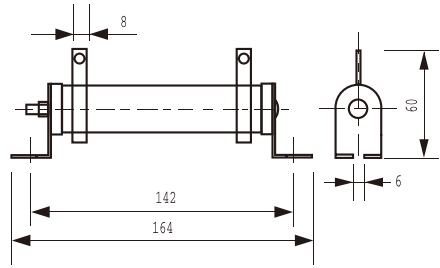

DDR80W50Ω J (80/50)

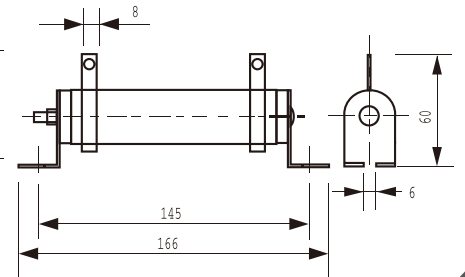

### EXTENDED BASE BRACKET

PF-083A PIN Base (8 PIN)



2-∅4.5  
Installation Hole

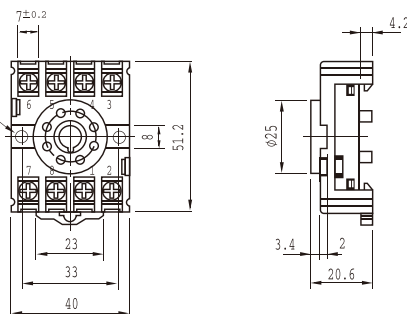

11-PFA PIN Base (11 PIN)

2-∅4.5  
Installation Hole

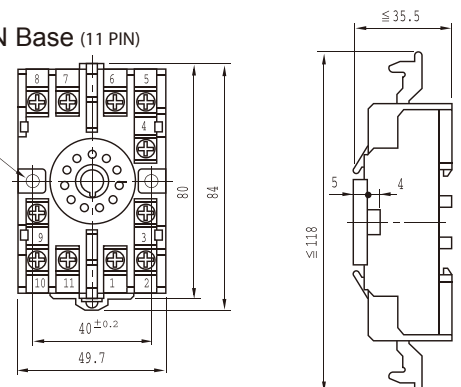

GENERAL PURPOSE MOTOR

SPEED CONTROLLED MOTOR

CONTROLLER

BRAKE MOTOR

CLUTCH BRAKE MOTOR

TORQUE MOTOR

SPEED REDUCER

COMPONENTS





599, Sec 1, Hemu Rd., Shengang, Taichung,  
42953, Taiwan  
TEL : +886-4-2561-0011  
FAX : +886-4-2562-7766  
www.sesamemotor.com  
info@sesamemotor.com.tw  
Skype Phone : sesame\_motor

Copyright ©2018 Sesame Motor Corp.  
All rights reserved



## MOTOR AND SPEED REDUCER

AGENT

---



---

V.3.0.02